



ISUZU



- 1
- 2
- 3
- 4
- 5
- 6
- 7
- 8
- 9
- 10
- 11
- 12
- 13
- 14
- 15
- 16
- 17
- 18
- 19
- 20
- 21
- 22
- 23
- 24
- 25

-



ISUZU

EURO II

4x2

ISUZU- NPR70L

REAR DUAL TIRE 4×2

(1 2

(2 2

ISUZU

(3 2

1384

(4 2

(5 2

(6 2

()

6700 mm

(1 3

2115 mm

(2 3

3000 mm

(3 3

3815 mm

(4 3

1680 mm

(5 3

1650 mm

(6 3

1900 mm

(7 3

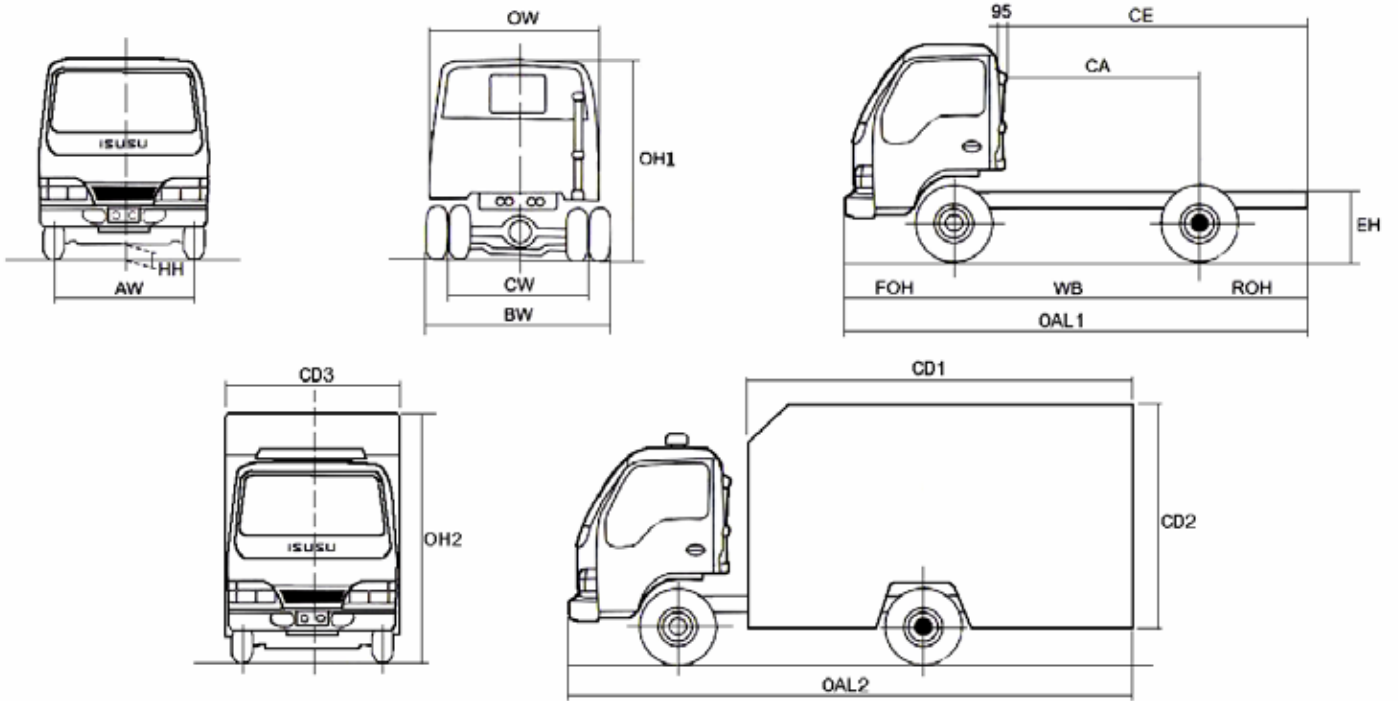

EH	HH	OH1	CW	BW	AW	OW	CA	CE	ROH	FOH	WB	OAL1
830	210	2220	1650	2115	1680	1995	3195	4910	1700	1085	3815	6600

OH2	CD1	CD2	CD3	OAL2
3000	5000	2550	2115	6700

()

4780 kg	(1 5
6000 kg	(2 5
	(3 5
3100 kg	(1 3 5
5000 kg	(2 3 5
	(4 5
2035 kg	1 4 5
2745 kg	2 4 5

	4	(1 6
2	2	(2 6
	2+1	(3 6
		(4 6
		(5 6
		(6 6
		(7 6
		(8 6
(P.P RESIN)		(9 6
		(10 6
		(11 6
		(12 6
		(13 6
		(14 6





()6495	(1 8
()935	(2 8
JIS-SAPH41	(3 8
8	(4 8

16"	(1 9
16"	(2 9
7/5 16	(3 9
7/5 16	(4 9
2	(5 9
REVERSE ELLIOT I-BEAM TYPE	(6 9
BANJO,FULLY FLOATING	(7 9
	(8 9
5/857 :1	(9 9
2035	(10 9
2745	(11 9
3100	(12 9
5000	(13 9

,

(1 10

,

(2 10

(3 10

(4 10

(5 10

(6 10

(1 11

(2 11

(3 11

(1 12

TWO LEADING, ,

(2 12

TWO LEADING, ,

(3 12

.

(4 12

EXHAUST BRAKE ()

(5 12

1 13

(1 1 13

(2 1 13

(3 1 13

(4 1 13

(5 1 13

2 13

(1 2 13

(2 2 13

(3 2 13

(4 2 13

1

24V 50A

(1 14

24 V 4/5 kW

(2 14

55 – 12 2

(3 14

(4 14

()

(5 14

()

,

(1 15

(2 15

4HE1-TCN(EURO-II

(1 16

)

(2 16

4

(3 16

125 mm

(4 16

110 mm

(5 16

4751 cc

(6 16

17.3:1

(7 16

133 hp

(8 16

355 N.m at 1200 to 2100 rpm

(9 16

810×700×800 mm³

(10 16

(11 16



300 mm :

DRY SINGLE PLATE

(1 18

(2 18

(3 18

-

MYY5T (1 19

(2 19

: (3 19

5/315 : 1

3/053 : 1

1/655 : 1

1/00 : 1

0/721 : 1

5/068 : 1

-

(1 20

2 (2 20

BANJO , FULL FLOATING , (3 20

5/857 : 1 (4 20

	—	
	<hr/>	
		(1 21
		(2 21
17.7L		(3 21
		(4 21
82°C		(5 21

	—	
	<hr/>	
108 km/h		(1 22
4.5 m		(2 22

	—	
	<hr/>	
13	SAE(15W-40)	(1 23
12	SAE(15W-40)	(2 23
4/3	SAE(15W-40)	(3 23
3/4	SAE(80W-90)	(4 23
0/5	DOT 3 grade	(5 23
1/6	Q-DEXRON III	(6 23
100		(7 23
2		(8 23
650±50	HFC-R134a	(9 23
17/7		(10 23



(1 24

(2 24

(3 24

(4 24

(5 24

/ (6 24

(7 24

(8 24

() (9 24

() (10 24





